

# Black Belt in Origami

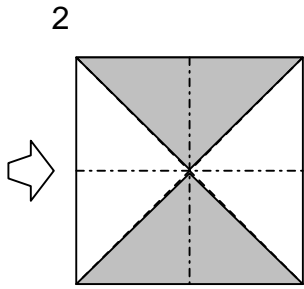

Preliminary fold

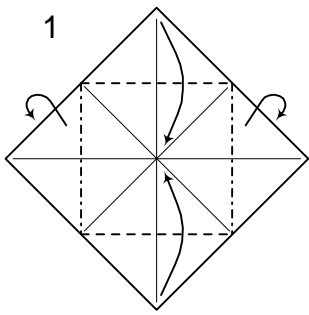
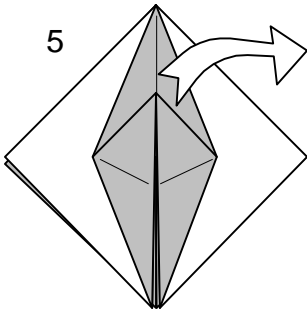
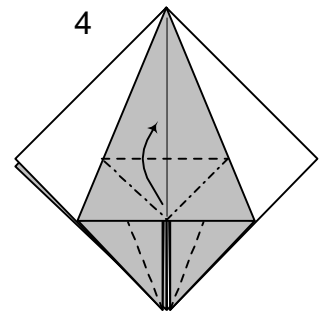
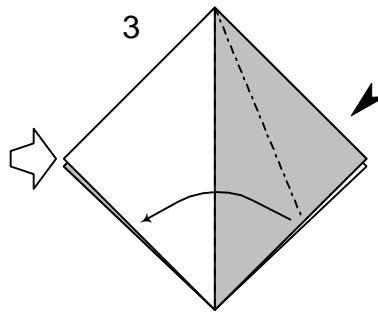

Pull out the loose paper (it helps if you unfold to step 4 first)

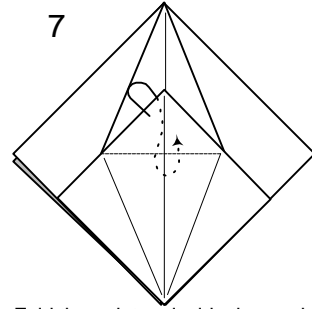
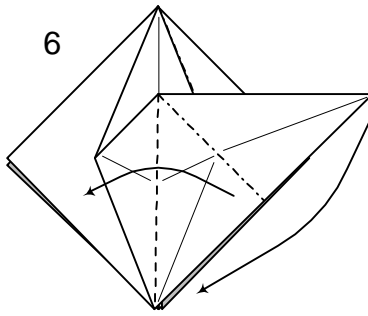

Fold the point up inside the model (you need to pull the model apart to do this)

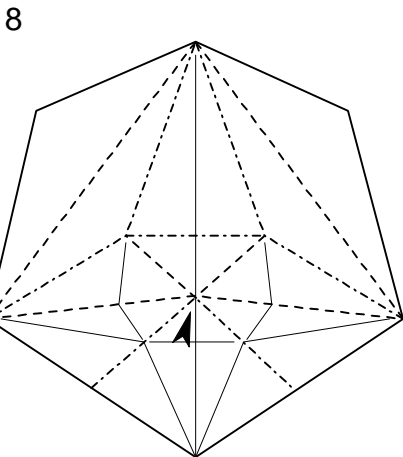

This is the half way stage

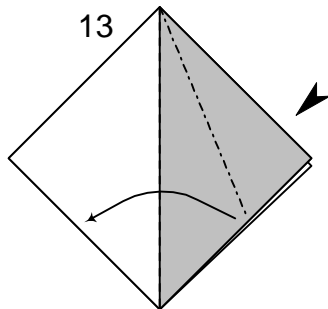
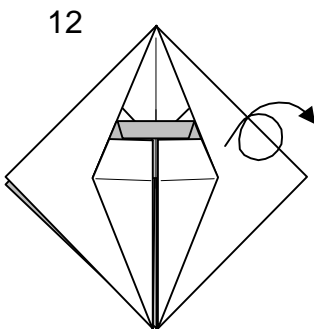
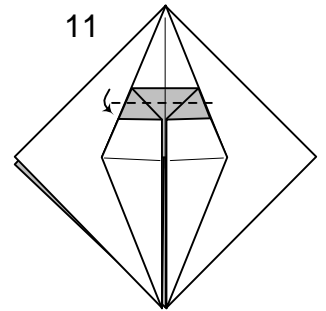
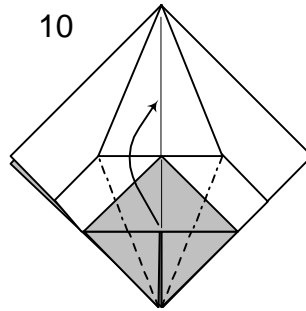
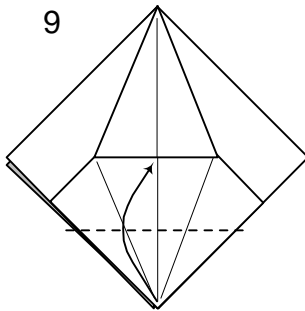

Repeat steps 3-8 on this side

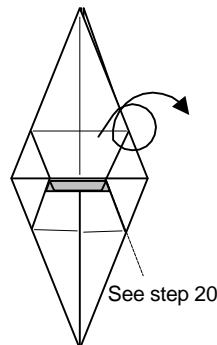
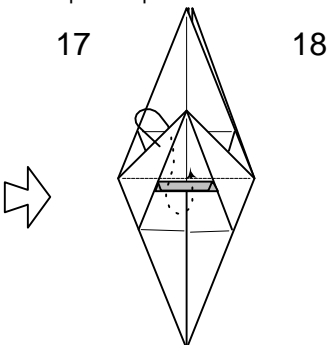
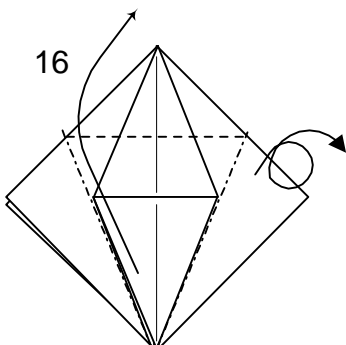
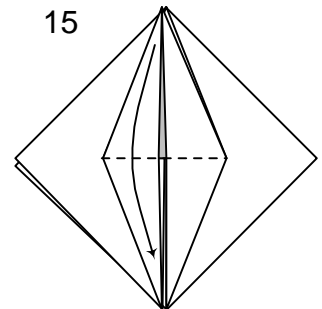
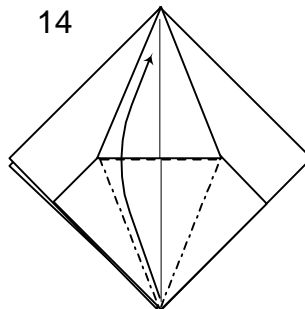

See step 20

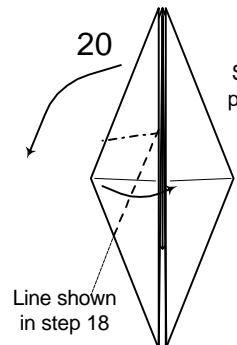
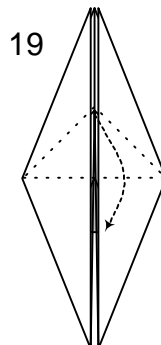

Swivel the point to the left

Line shown in step 18

Fold the point up inside the model (much harder than step 7!)

# Black Belt in Origami

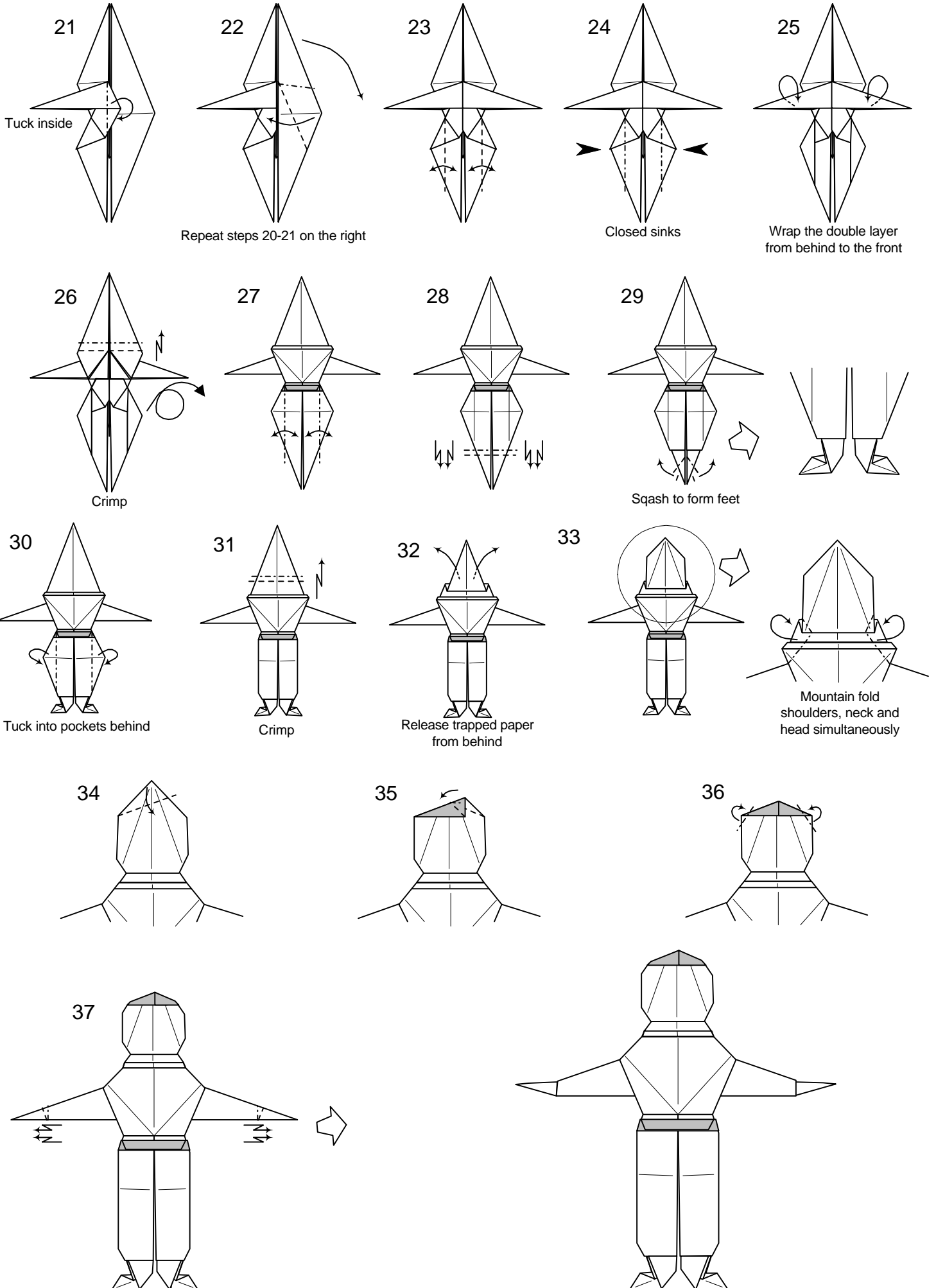

Liens vers type 1



<http://www.ciberlibreria.info>



<http://www.cyberlibrairie.info>



<http://www.cyberlibreria.info>



<http://www.epapier.net>



<http://www.etheque.info>



<http://www.jelis.info>



<http://www.librairievirtuelle.info>



<http://www.livre-cd-gratuit.com>



<http://www.livres-electronique.com>



<http://www.telecharger-livre.com>



<http://www.webrairies.info>

# WLBrairie

La librairie du web

<http://www.webrairie.com>



Distribuez vos livres :

<http://www.webrairie.com/editeur/index.php>