

7.

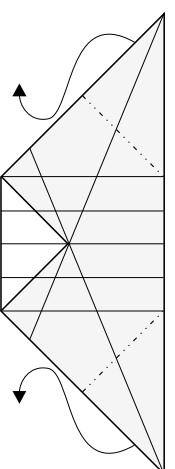

8.

Inside reverse folds.

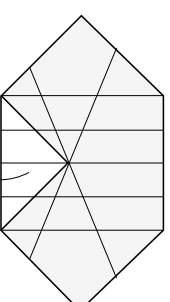

9.

Unfold.

Squash fold. The valley fold is on an existing crease.

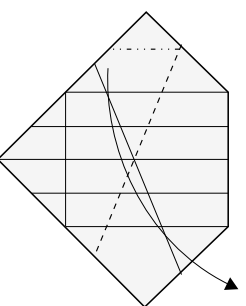

10.

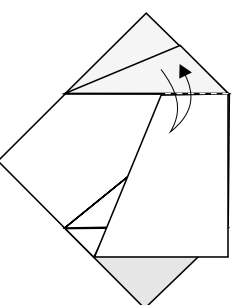

11.

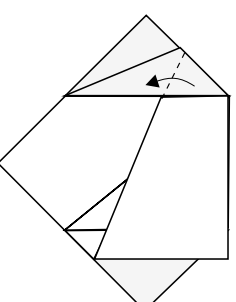

12.

Three-Banded Armadillo ©1993 by Joseph Wu

Repeat steps 10-12 three times:
on the right and on the back.

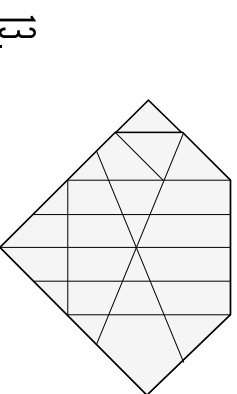

Repeat behind.

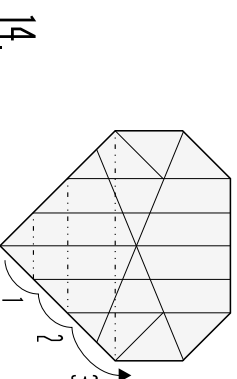

Repeat behind.

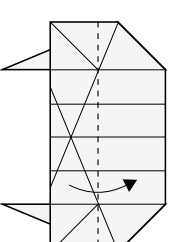

Repeat behind.

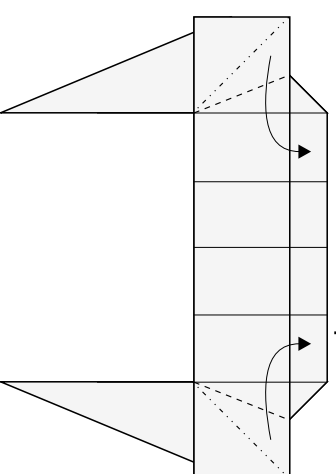

Repeat behind.

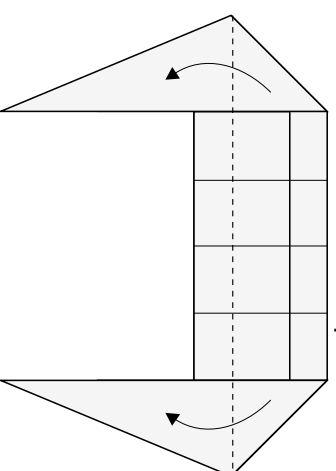

Unfold. Repeat behind.

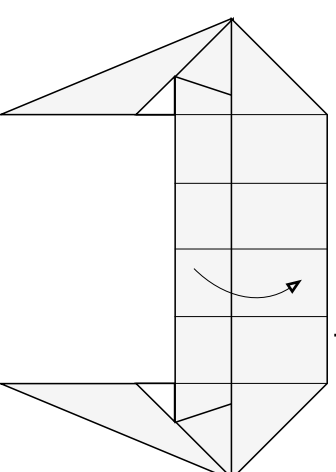

Three-Banded Armadillo ©1993 by Joseph Wu

Fold middle inside and up.
Repeat behind.

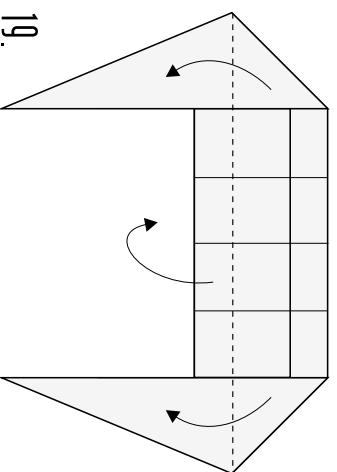

Fold and unfold on both lines.

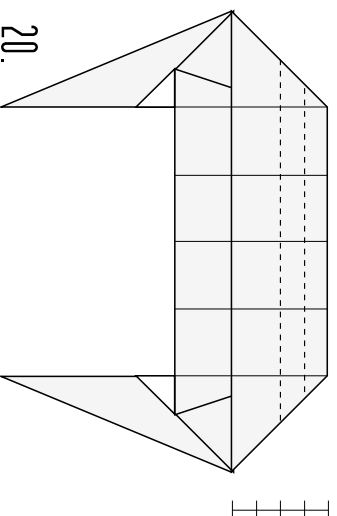

Sink down and up.

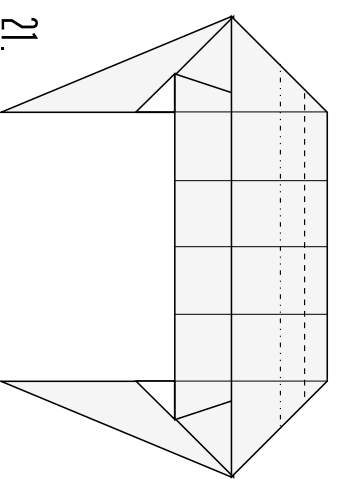

Repeat behind.

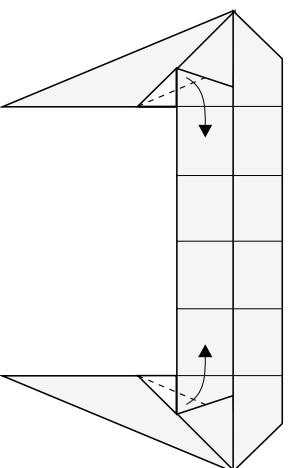

Repeat behind.

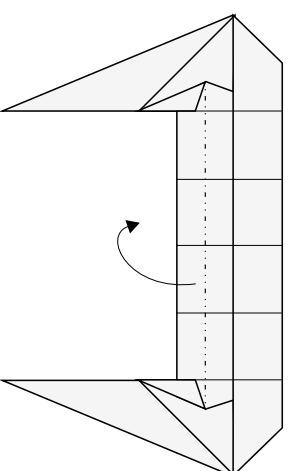

Repeat behind.

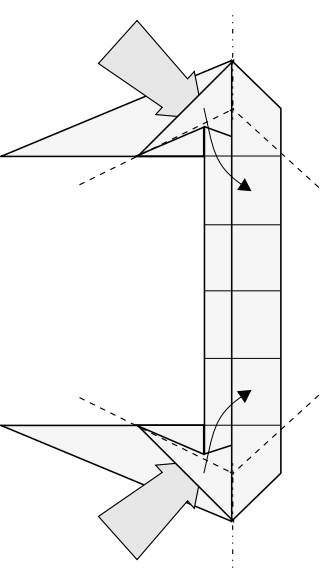

22.

23.

24.

Repeat behind.

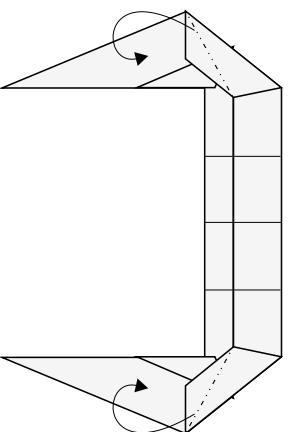

25.

Repeat behind.

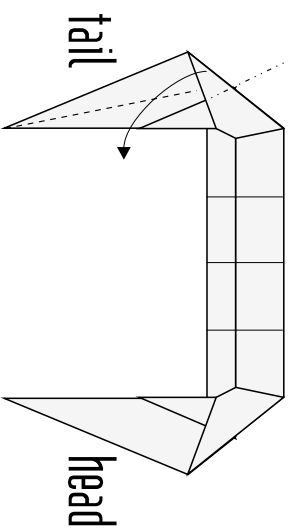

26.

Inside reverse folds.

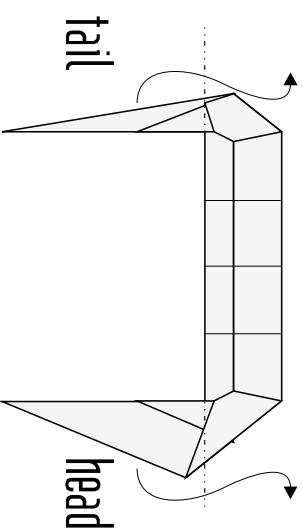

27.

1. Inside reverse fold.

2. Outside reverse fold.

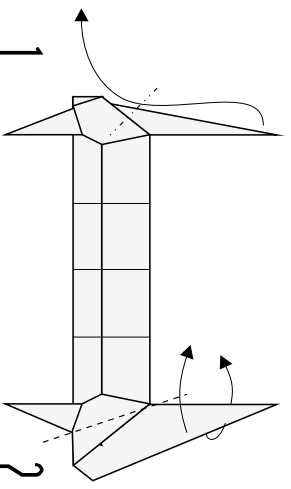

28.

1. Fold both sides down.

2. Outside reverse fold.

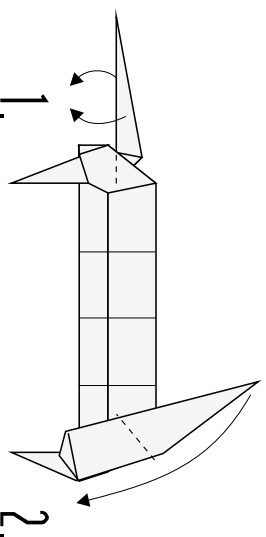

29.

Crimp folds.

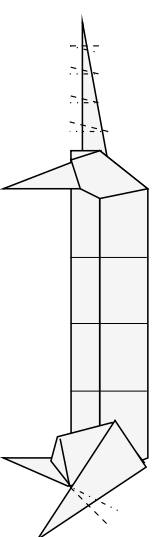

30.

Three-Banded Armadillo ©1993 by Joseph Wu

1. Reverse fold.
2. Swivel fold. Repeat behind.

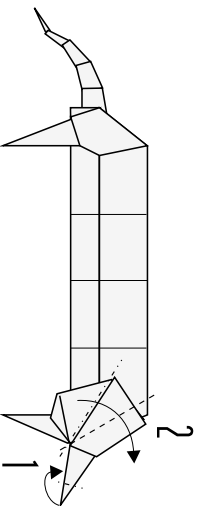

31.

- Inside reverse folds.
Repeat behind.

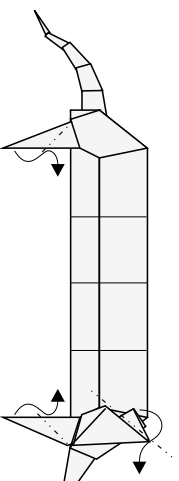

32.

- Inside reverse fold front legs. Bend ears down slightly. Repeat behind.

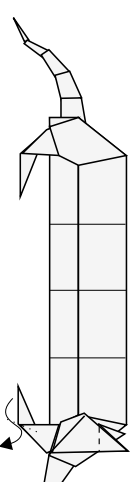

33.

This is the result of the folding so far. The final steps are involved with making the model three-dimensional.

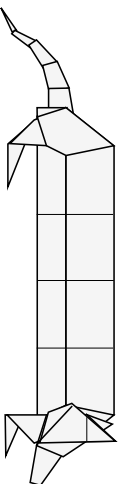

34.

Spread the bottom of the model so that the extra layers of paper made in step 21 are exposed.

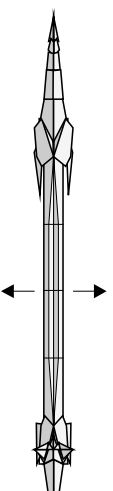

35. Top view.

Pleat the resulting dome shape. Note that the middle crease is crooked at the ends.

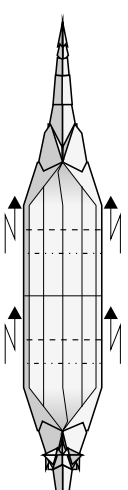

36. Top view.

Three-Banded Armadillo ©1993 by Joseph Wu

This is the result of the pleating.

Lock the pleats into place
(hidden layer inside).
Repeat behind.

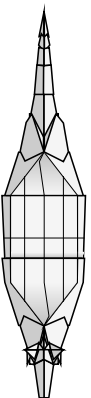

37. Top view.

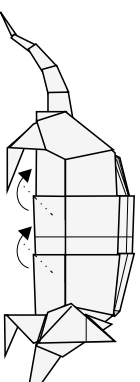

38. Side view.

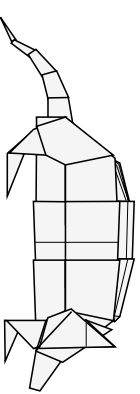

39. The completed armadillo.

Notes:

1. The head does not look very "animal-like" when compared to the heads of other origami animals, but I have tried to recreate as accurately as possible the distinctive shape of the armadillo's head.
2. This model is the result of a challenge made to me by a friend (a non-folder) in November 1992. The breakthrough in the creation of this model occurred in April 1993 when I decided to modify Montroll's "brontosaurus base" as a starting point. The model was completed in May 1993.

Liens vers type 1



<http://www.ciberlibreria.info>



<http://www.cyberlibrairie.info>



<http://www.cyberlibreria.info>



<http://www.epapier.net>



<http://www.etheque.info>



<http://www.jelis.info>



<http://www.librairievirtuelle.info>



<http://www.livre-cd-gratuit.com>



<http://www.livres-electronique.com>



<http://www.telecharger-livre.com>



<http://www.webrairies.info>

W^LB^rairie

La librairie du web

<http://www.webrairie.com>



Distribuez vos livres :

<http://www.webrairie.com/editeur/index.php>