

The Martian Bouncing Spider

copyright 1997 by Perry Bailey

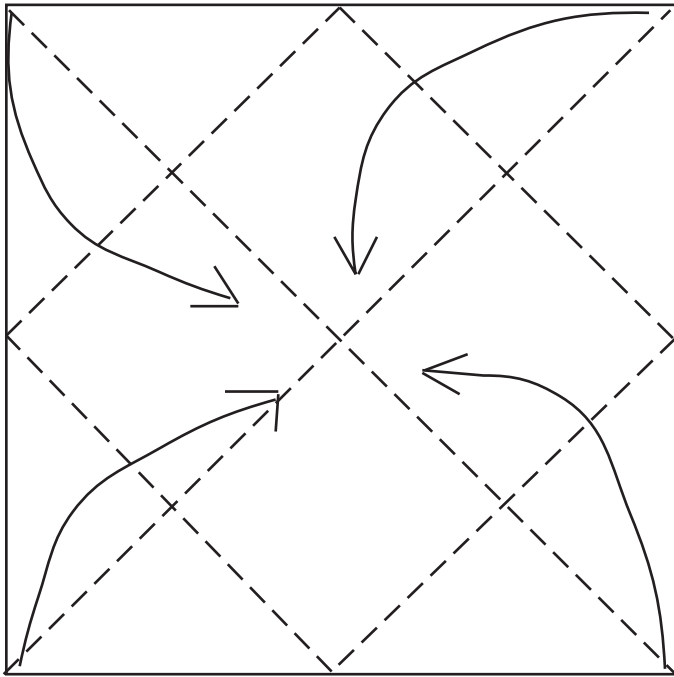

1. fold and unfold paper diagonally in half both ways then blintz fold in all the corner to the center.

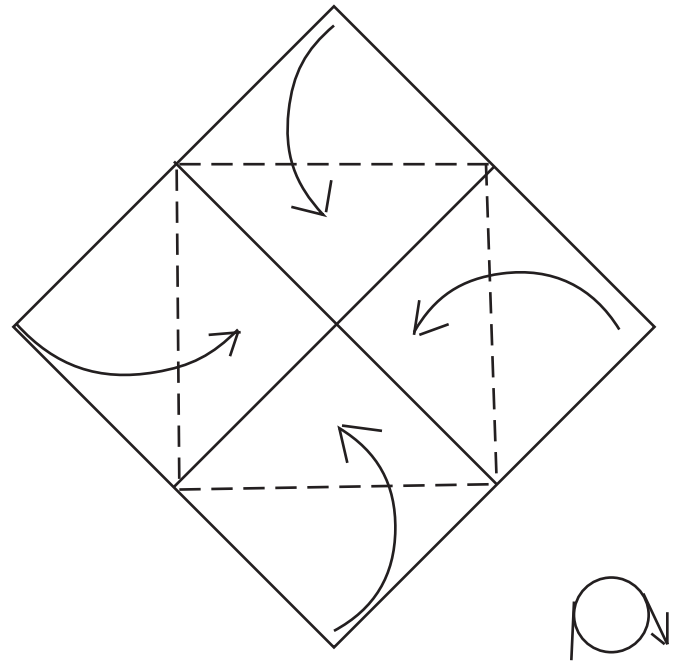

2. Blintz fold again the center. Then unfold completely and turn the model over.

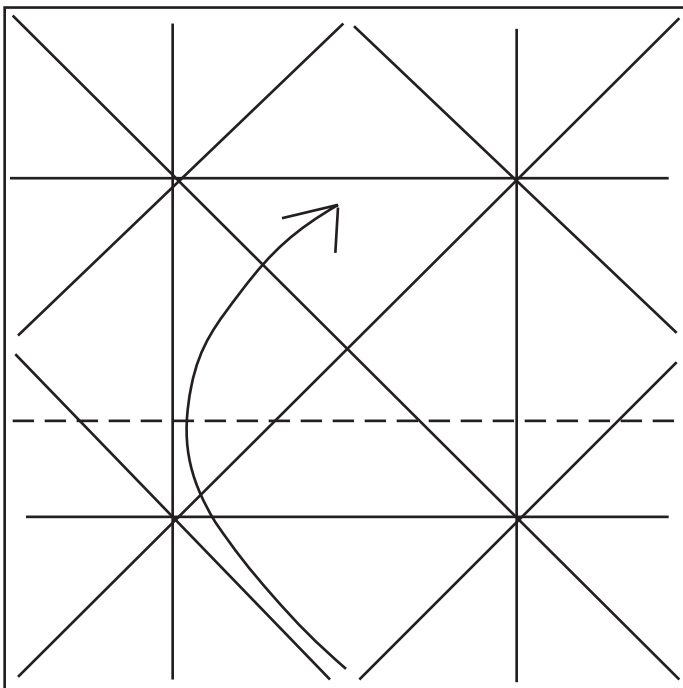

3. Fold the raw edge up to the top crease, then unfold and repeat on other 3 sides. Turn the model over.

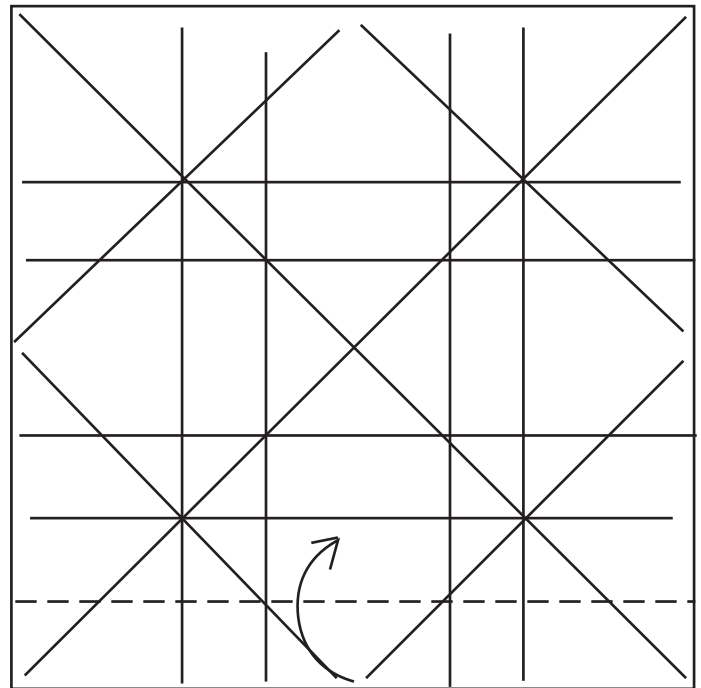

4. Fold the raw edge up to the first crease, then unfold. Repeat on other 3 sides.

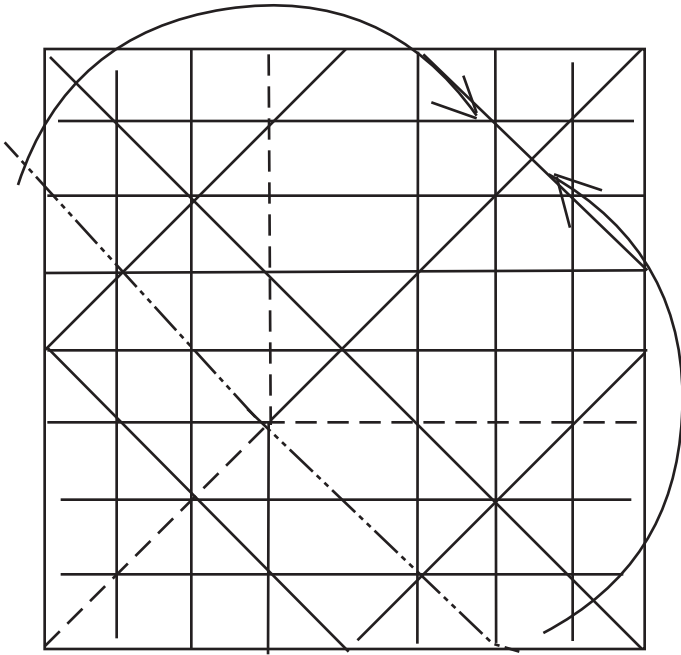

5. Make a really large rabbits ear, then unfold and repeat on the other three corners.

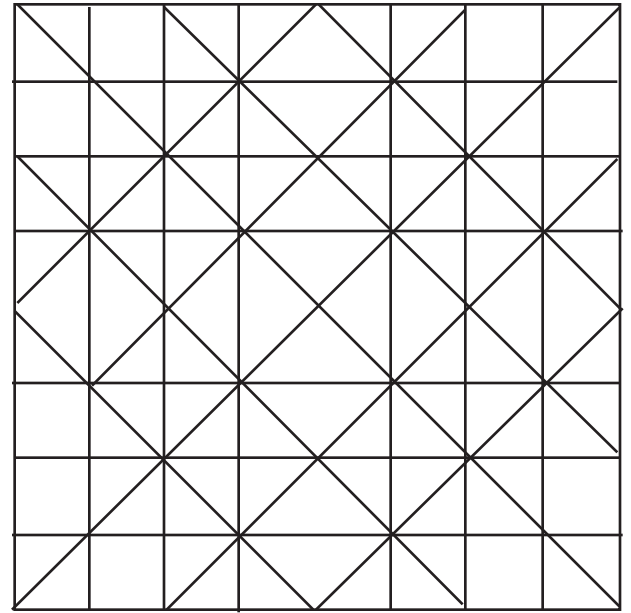

6. This is all of the folds after step 5, from here we go to the crease pattern to fold this into a long armed windmill.

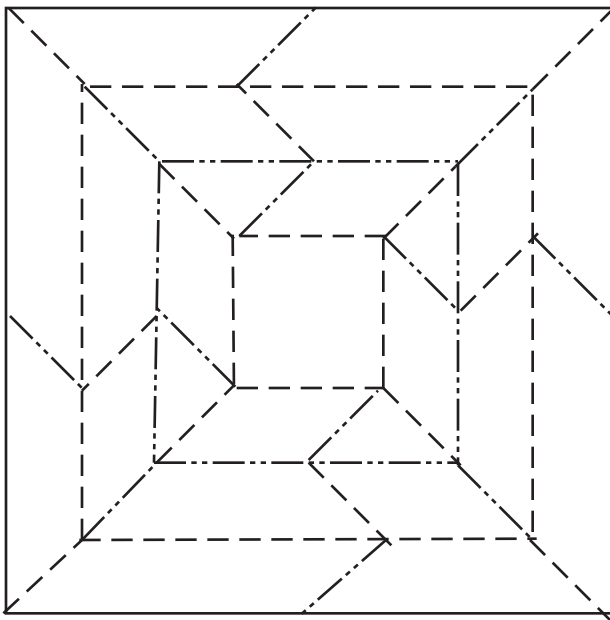

7. Collapse the model in to a long armed pinwheel.

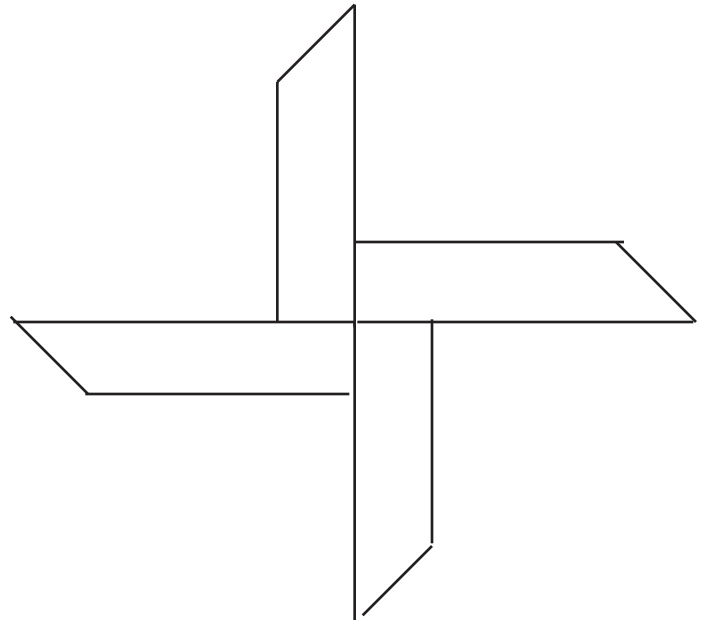

8. The model should have collapsed into a large pinwheel type shape. Note the small square in the center of the model remains flat through out the collapse. In the next diagram you will see only 1 arm shown.

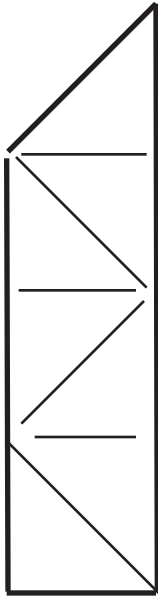

9. Notice creases on the arm of the model, the next step is to use these creases to fold each arm into 3 preliminary base each one opposite to the one before.

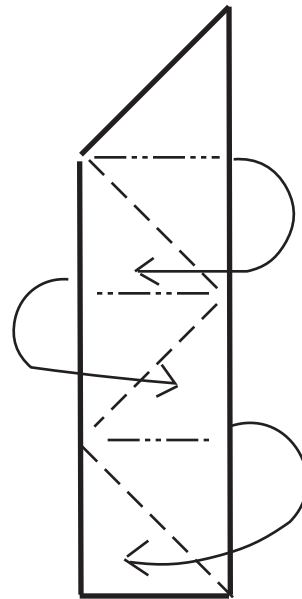

10. Note that the bottom most preliminary base is four layers, put two layers to each side, the other folds will be only 1 layer each.

11. Three layers of preliminary bases on on top the other.

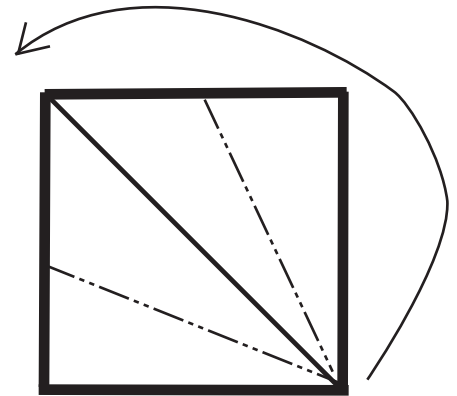
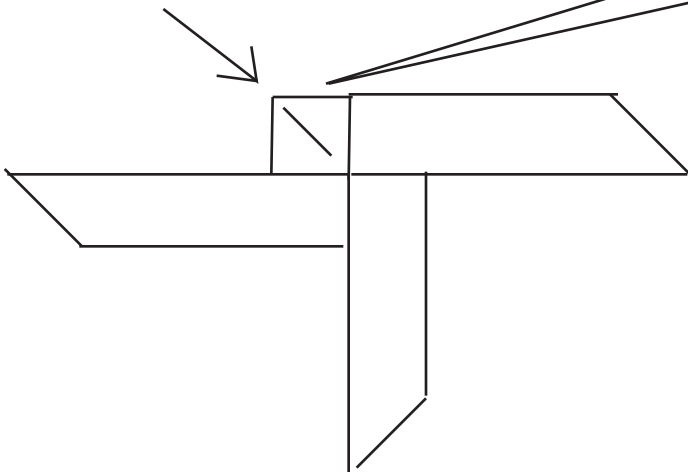

12. This is an enlarged view of the leg we just folded. Now we fold half of a bird base.

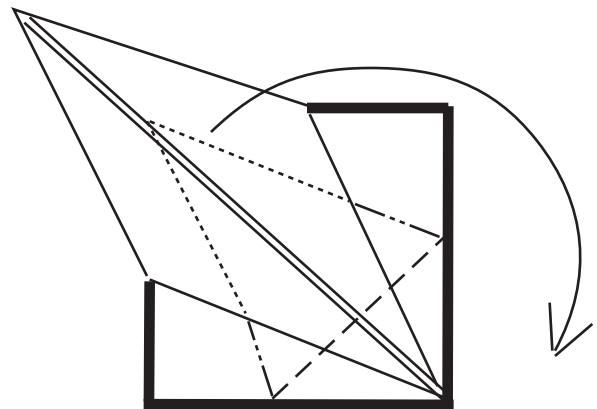

13. Fold another half of a bird base, but in the opposite direction.

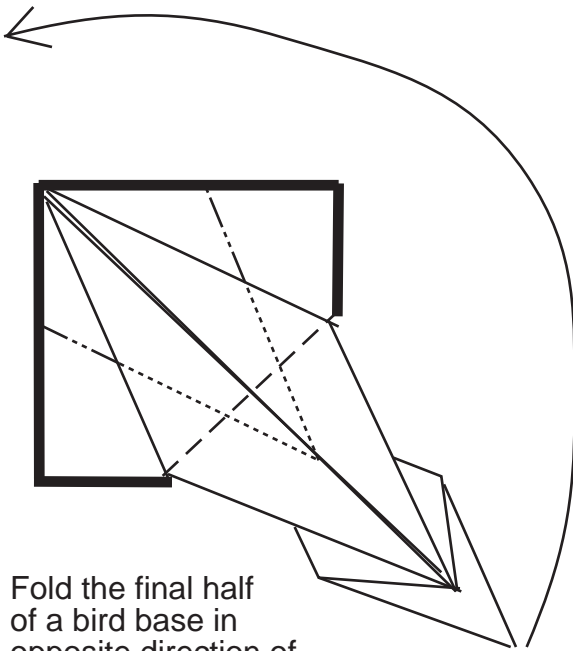

14. Fold the final half of a bird base in opposite direction of the previous one.

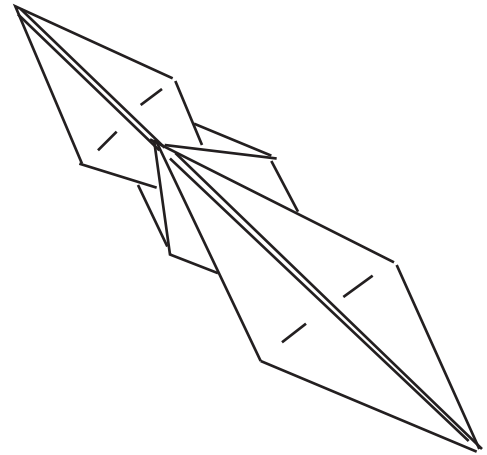

15. Finished view of one leg.

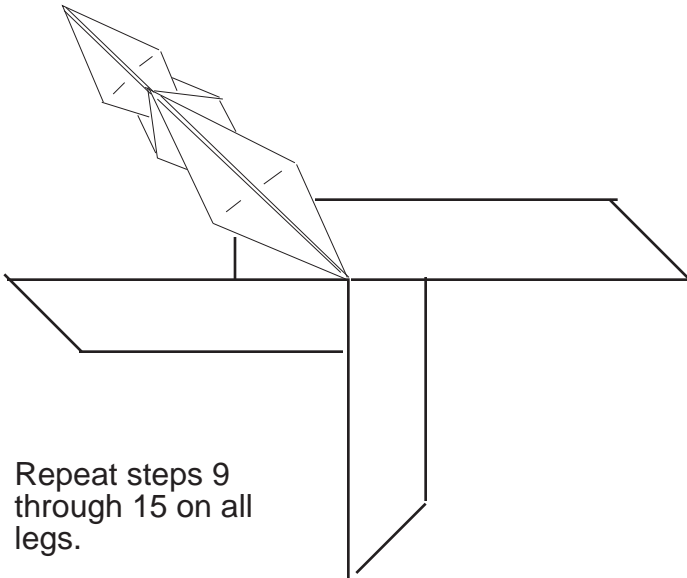

16. Repeat steps 9 through 15 on all legs.

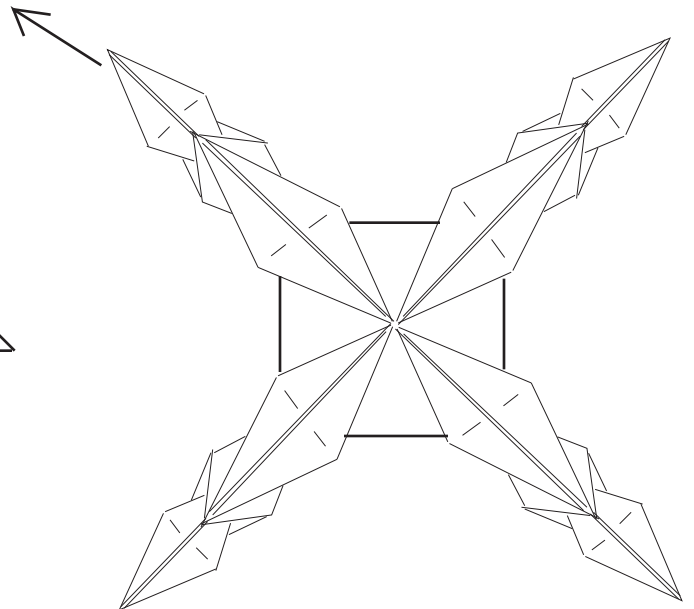

17. Now to finish your martian bouncing spider, grab the tip of each leg one at a time and gently pull in out till the middle of the leg becomes tube like.

Odd note here if you feel the need to improve your spiders bounce some careful wet folding at the end, or glue if you want to hold the square part of his body together, or just use stiff paper like I do and it should work just fine! Perry

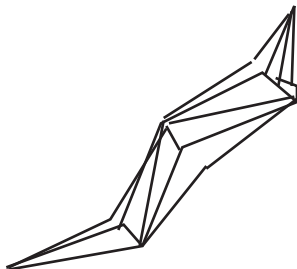

18. Each leg will pull out like this.

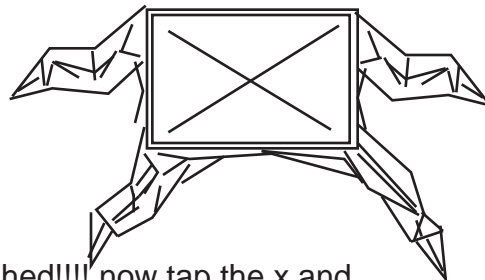

Finished!!!! now tap the x and watch him bounce! With practice you can even dribble your spider.

Liens vers type 1



<http://www.ciberlibreria.info>



<http://www.cyberlibrairie.info>



<http://www.cyberlibreria.info>



<http://www.epapier.net>



<http://www.etheque.info>



<http://www.jelis.info>



<http://www.librairievirtuelle.info>



<http://www.livre-cd-gratuit.com>



<http://www.livres-electronique.com>



<http://www.telecharger-livre.com>



<http://www.webrairies.info>

WLBrairie

La librairie du web

<http://www.webrairie.com>



Distribuez vos livres :

<http://www.webrairie.com/editeur/index.php>